

DATASHEET

# M20071-1

M20071-1•GNSSNOVA

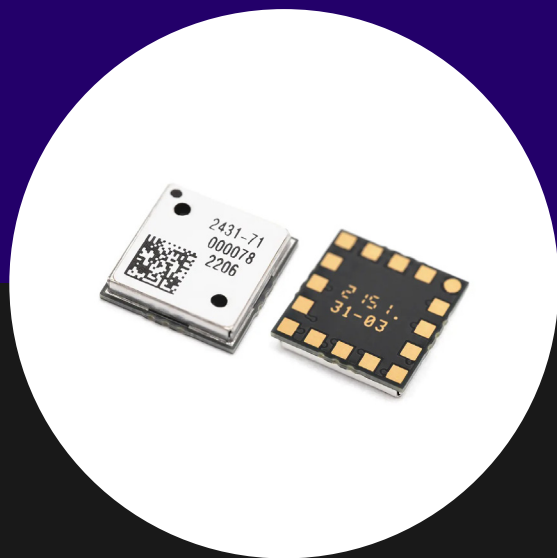

## Features

- Multi-constellation GNSS receiver (GPS/GLONASS/GALILEO/BEIDOU/QZSS)
- Full function GNSS module
- MediaTek AG3335MN flash chip
- Ultra-small SMD package; 9.0 x 9.0 x 1.8mm
- Low current consumption
- AIC, Active Interference Cancellation
- EASY - Internally generated orbit prediction for fast fix times
- EPO (Extended Prediction Orbit) fast fix

# 1. Description

An integrated GNSS receiver module incorporating the MediaTek AG3335MN flash chip. The receiver tracks 4 GNSS constellations concurrently (GPS+Galileo+GLONASS+Beidou). 12nm process with 1.8V system power supply provides outstanding low power consumption. Multi-path algorithms improve position accuracy in inner-city environments. The on-board LNA provides good performance in weak-signal environments such as wearable devices.

# 2. Applications

- Wearable devices such as Fitness watches
- Portable devices
- Asset tracking / Personal safety
- Vehicle trip recording cameras
- Sports electronics such as Golf computers
- Navigation systems

# 3. Part number

M20071-1

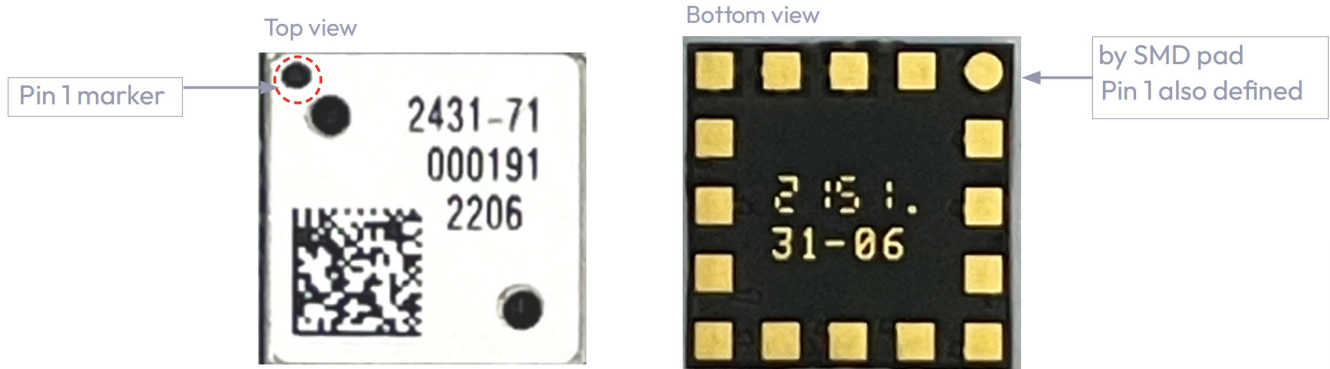

## 4. Functional block diagram

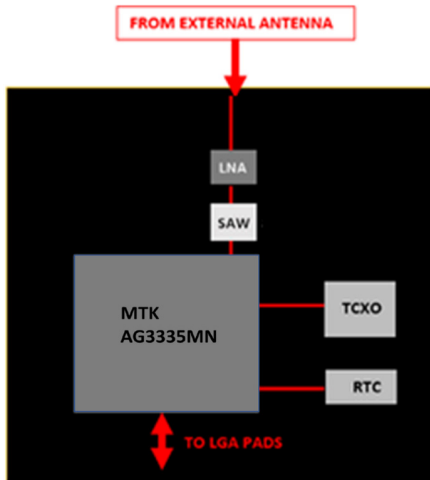

## 5. Module specifications

### 5.1. Absolute maximum ratings

SYMBOL	PARAMETER	MIN	MAX	UNIT
VIN_SYS	Main supply voltage for System	0	1.98	V
VIN_RTC	Supply voltage for RTC mode	0	1.98	V
VIO_1V8	Supply voltage for 1.8V I/O	0	1.98	V
VIO_2V8*	Supply voltage for 2.8V I/O	0	3.08	V
RF <sub>IN</sub>	Maximum RF input power	N/A	0	dBm
T <sub>STG</sub>	Storage temperature	-40	+85	°C
T <sub>OP</sub>	Operating temperature	-40	+85	°C

Exposure to absolute ratings may adversely affect reliability and may cause permanent damage.

\*If 2.8V I/O will be applied, please connect VIO\_1V8 with 2.8V LDO's enable pin for power sequence constraint.

### 5.2. Recommended operating conditions

SYMBOL	PARAMETER	MIN	TYP	MAX	UNIT
VIN_SYS	Main supply voltage for System	1.62	1.8	1.98	V
VIN_RTC	Supply voltage for RTC	1.62	1.8	1.98	V
T <sub>OP</sub>	Operating temperature	-40	-	+85	°C

### 5.3. DC electrical characteristics

Conditions: VIN\_SYS = 1.8V, VIN\_RTC = 1.8V, TOP = 25 °C

SYMBOL	PARAMETER	TYP	UNIT
I <sub>CC(ACQ)</sub>	Acquisition mode current	18	mA
I <sub>CC(TRK)</sub>	Tracking mode current	12	mA
I <sub>CC(STBY)</sub>	RTC mode current	<100	µA

### 5.4. RF specifications

Conditions: VIN\_SYS = 1.8V, VIN\_RTC = 1.8V, TOP = 25 °C, Freq = 1575.420MHz

SYMBOL	PARAMETER	TYP	UNIT
NF <sub>LNA</sub>	LNA Noise Figure (AG3335 Integral LNA)	3.0	dB
NF <sub>LNA1st</sub>	1 <sup>st</sup> Stage LNA	1.07	dB

### 5.5. Band rejection

FREQUENCY	STANDARD	TYP*	UNIT
698-798	LTE700	39	dB
824-849	Cellular CDMA	39	dB
869-894	GSM850	39	dB
880-915	GSM900	38	dB
1710-1785	GSM1800/DCS	38	dB
1850-1910	GSM1900/PCS	38	dB
1920-1980	WCDMA	39	dB
2400-2492	WLAN, BT and WiMAX	43	dB
2500-2690	LTE2600	45	dB

Note: Does not include antenna rejection.

## 5.6. Mechanical specifications

PARAMETER	TYP	UNIT
Module exterior dimensions (L x W x H)	9.0 (±0.1) x 9.0 (±0.1) x 1.8 (+0.2 / - 0.0)	mm
Module support and connection	Surface mounted (SMD)	-
Module mass	≤0.8	g

## 5.7. System specifications

COMMUNICATION	SPECIFICATION
Data Output Protocol	NMEA 0183
Host Interfaces	UART
Default data rate on UART	115200bps default rate, modify by input command
GPS ENGINE	
Chip	MTK AG3335MN Flash Chip
Channels	GPS+Galileo+GLONASS+Beidou
TCXO	0.5ppm
ACCURACY	
Horizontal position accuracy	<2.5m CEP
Maximum position update rate	10 Hz (Default 1Hz)
SENSITIVITY	
Acquisition (Cold)	-148dBm
Tracking	-165dBm
TTFF	
Hot start	<1s
Warm start	<25s (typical)
Cold start	<35s (typical)
GENERAL	
Maximum altitude	<10 km
Maximum speed	<514 m/s
Active interference cancellers	12 multi tone active cancellers; ISSCC2011 award
Additional features	1PPS Sync, SBAS, WAAS, EGNOS, QRZZ, GAGAN support
EPO / EASY	Orbit prediction

50% CEP, Open-Sky, 24hr Static, -130dBm, good view of the sky

## 6. Module dimension

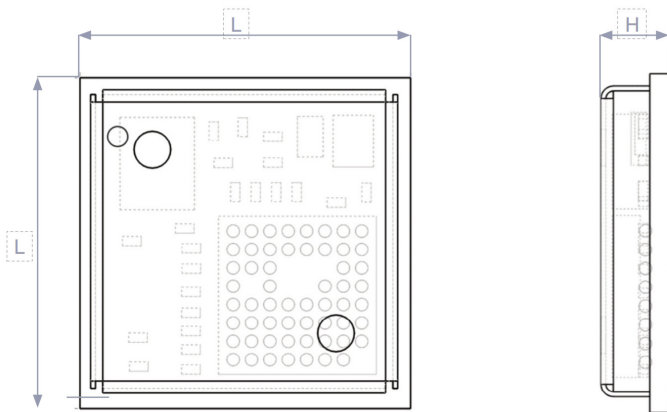

L	W	H
Length	Width	Height
13.8 ±0.1	9.5 ±0.1	1.8 ±0.2 / -0.0

All dimensions in (mm)

## 7. Schematic symbol and pin definition

PIN	DESIGNATOR	DESCRIPTION
1	GND	Ground connection (Round pad)
2	RF_IN	RF connection from antenna (50Ω)
3	GND	Ground connection
4	GND	Ground connection
5	GND	Ground connection
6	N.C	No connect
7	CHIP_EN	System reset, active low
8	GNSS_DATA_EINT	Handshaking with host
9	VIO_2V8	2.8V input for 2.8V I/O support
10	VIO_1V8	1.8V output for 1.8V I/O support
11	UART_RX	UART interface receive data line
12	UART_TX	UART interface transmit data line
13	RTC_EINT	To wake up module from RTC mode
14	PPS	Pulse per second output
15	VIN_SYS	Main supply voltage, 1.8V in TYP
16	VIN_RTC	RTC supply voltage, 1.8V in TYP

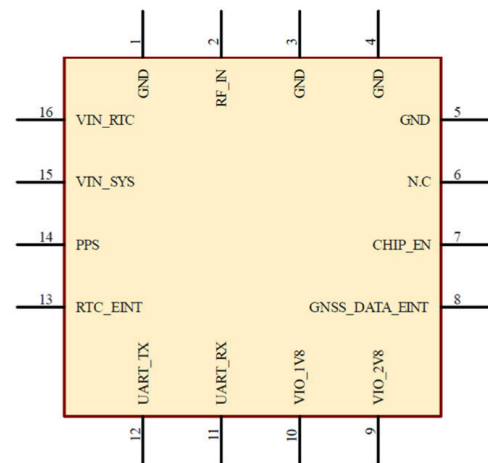

## 8. Host PCB footprint

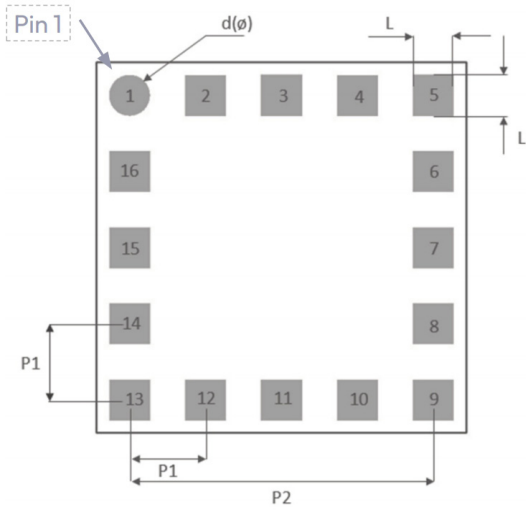

L	P1	P2	D(∅)
Pad Size	Pad pitch	Pitch total	Diameter pad 1
1.0	1.85	7.40	1.0

All dimensions in (mm)

## 9. Module subsystem feature

The circuit below shows a basic design for 1.8V I/O interface.

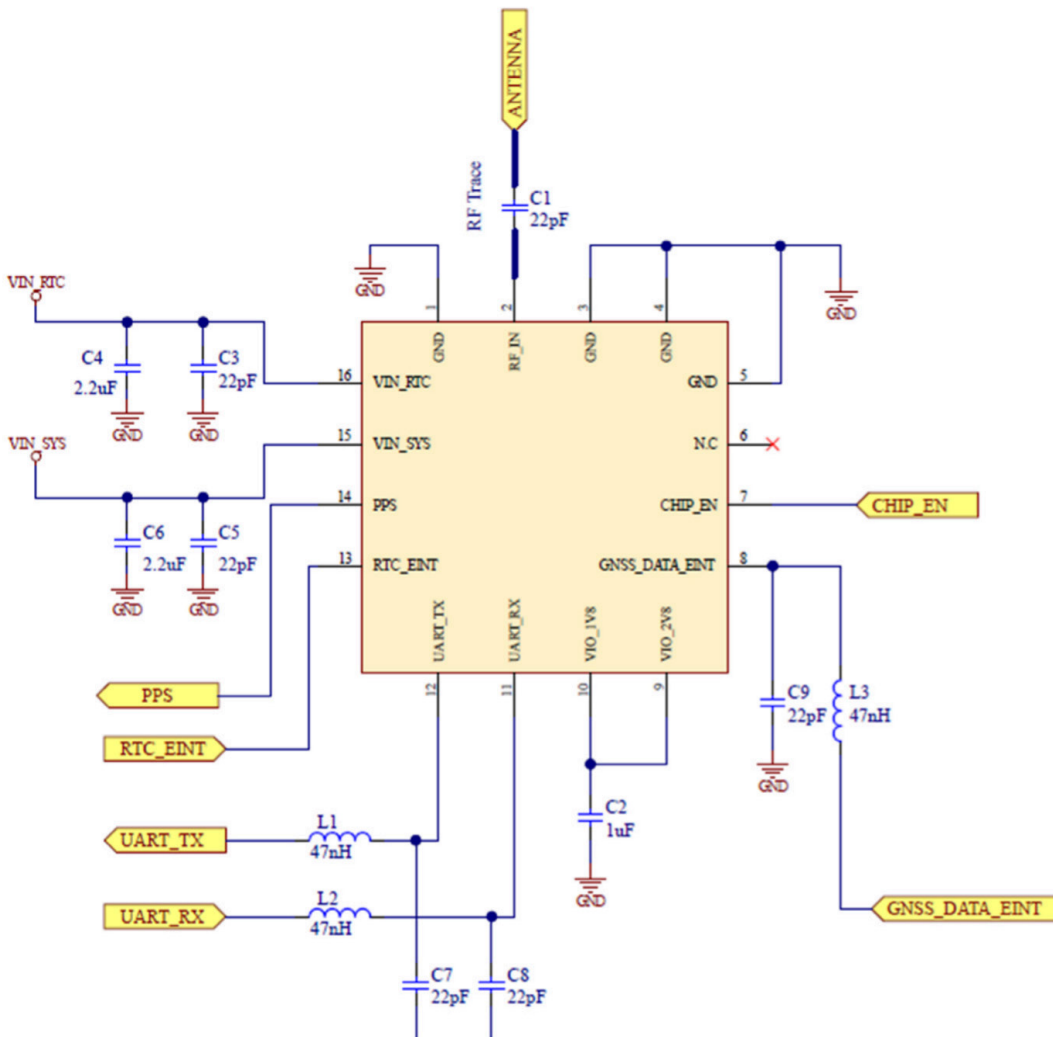

### Bill of Material

DESIGNATOR	VALUE	DESCRIPTION/COMMENTS	QUANTITY
C3, C5, C7, C8, C9	22pF capacitor	Decoupling cap. Place close to corresponding pin	5
C4, C6	2.2uF capacitor	Decoupling cap. Place close to corresponding pin	2
L1, L2, L3	47nH Inductor	Filter component	3
C1	22pF capacitor	DC block	1
C2	1uF capacitor	Decoupling cap. Place close to pin10	1

Information and all such information shall be entirely at the user's risk.

## 10. Module subsystem feature

### 10.1. Host interface

The UART interface is used for M20071 to provide full-serial data communication channels between M20071 and host. The UART communication function includes UART data transmit/receive, GNSS NMEA sentence input/output, and MTK command input.

The UART supports standard baud rate and can be changed after bootup by using the relevant command. Please contact Antenova for more information about the baud rate configuration.

GNSS\_DATA\_EINT on M20071 pin8 is for handshaking with host to avoid missing command and needs to connect to host UART RTS.

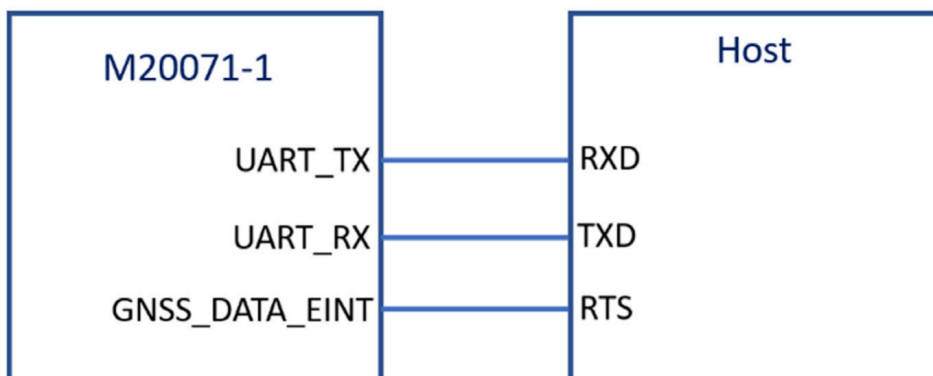

### 10.2. External matching

The M20071 uses 1.8V DC power inputs. VIN\_SYS is main power supply for the core system, and VIN\_RTC is power supply for RTC clock and RTC RAM. M20071 supports power saving mode (RTC mode), and it needs standalone VIN\_RTC in the design for support RTC mode.

### 10.3. Power constraint for 2.8V IO

The voltage level of the IO interface is 1.8V only. If 2.8V IO needs to be applied, there's a power sequence constraint for 2.8V IO application.

Connect VIO\_1V8 (pin10) to 2.8V LDO's enable pin, so that the 2.8V for VIO\_2V8 (pin9) will be powered up after VIO\_1V8.

## 10.4. Pulse Per Second (PPS)

PPS (pulse per second) is a pulse signal output from the M20071, repeating an accurate synchronized pulse signal once per second. The pulse width is 100ms by default, and can be configured from 50ms to 999ms by using MTK command. The PPS function is enabled by default, and module will output PPS signal once the 3D-fix is completed. Please contact Antenova for more information about the PPS pulse width configuration.

## 10.5. HRST (Hardware reset pin)

The CHIP\_EN pin is for hardware reset function and is internal pull-high. To initiate a hardware reset, the pin needs to be pulled low for 10ms.

## 10.6. Power saving mode

The M20071 has three power saving modes.

- OFF mode
- RTC mode
- Periodic mode

### 10.6.1. OFF mode

OFF mode is controlled by the CHIP\_EN pin. When CHIP\_EN is low, only the power management logic is active, and all other logic is powered down.

### 10.6.2. RTC mode

RTC mode is a low-power mode that shuts down the system core. When system goes in to the RTC mode, all the commands cannot be sent and the module no longer provides position-related information. The navigation data is saved to RTC-RAM, and when the system is woken up, this data is used to regain a position fix.

The chip is woken up by pulling the RTC\_EINT pin high for 1ms. Once the module exits the RTC mode, all system resources will be re-initialized. The navigation data will be loaded from RTCRAM. If all the data are valid, it will facilitate the TTFF performance

M20071 support software RTC mode by sending the MTK command listed in below:

RTC MODE COMMAND	EXIT RTC MODE
\$PAIR650,0	Pull-High RTC_EINT for 1ms

### 10.6.3. Periodic mode

Periodic mode is a module controlled mode that reduces current consumption by module running and sleeping periodically to maintain fixed data.

The periodic state can be configured by users base on their needs. Contact Antenova for more information and a user command manual.

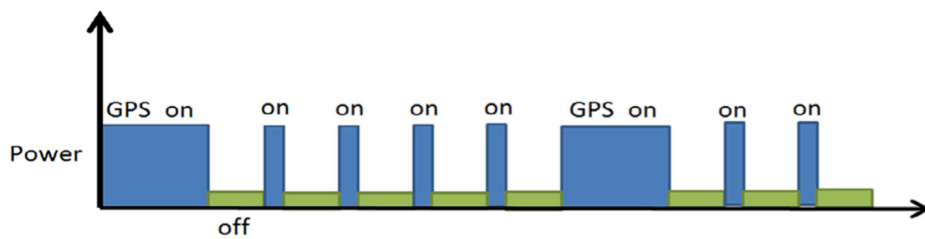

COMMAND (EXAMPLE)	M20071 TIME FOR OFF/AWAKE
\$PAIR690,1,21,39,48,72	Module sleep 39s then run 21s in signal condition; Module sleep 72s then run 48s in no signal condition.

### 10.7. EPO (Extended Prediction Orbit) data service

The EPO allows the use of up to 30-day orbit predictions that can be used to aid the module for an instant fx solution.

- A proxy server on the customer’s side to update EPO files from the MTK server daily.
- Application software to access the proxy server through the internet (optional if host device can access internet).
- Software on host device to send EPO data to M20071 module to allow instant fx by using EE data. Please contact Antenova for more information. Requires permission from MTK to use service.

### 10.8. EASY (Self-Generated Orbit Prediction)

The M20071 module supports EASY (Embedded Assisted System). EASY is an Orbit Prediction feature that speeds up TTFF (time to first fx) performance. EASY provides up to 3 days of GPS orbit predictions, and it does not require an internet connection or software running on a host processor. EASY within the GNSS receiver and accelerates TTFF by calculating a predicted satellite orbits (called the ephemeris). The calculations performed by EASY are scheduled during normal operation of the GNSS receiver. EASY is switched on by default and can be disabled by a PMTK command.

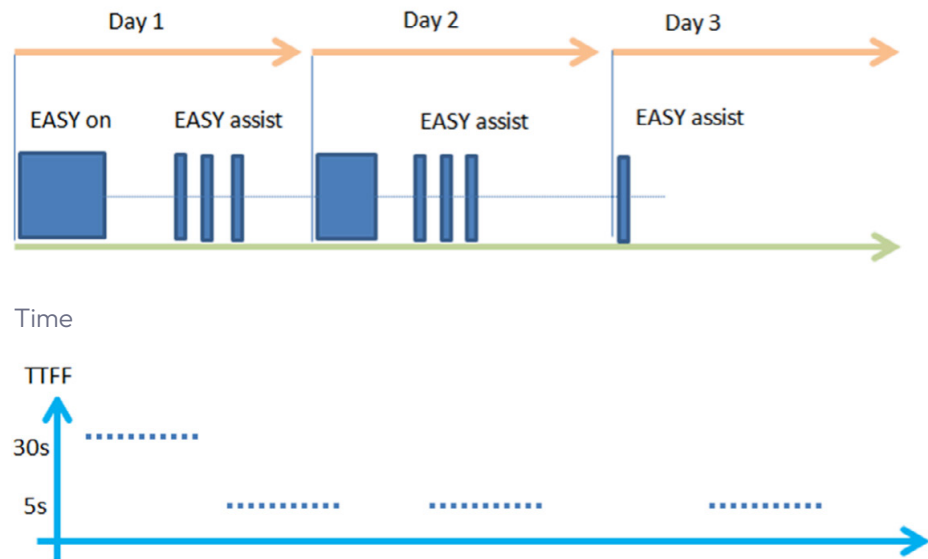

### 10.9. AIC (Active Interference Cancellation)

The AIC feature provides effective narrow-band interference cancellation. The GPS signal can be recovered from signals that contain interference signals. High speed processors generate clock harmonics that cause interference to be present within the GPS band.

# 11. Evaluation kit

## 11.1. GNSS evaluation

The EVK is a single PCB that contains the M20071 module and required components to run on a PC via a USB cable.

Evaluation kits are available on request. Please contact Antenova for more information. (Part number: M20071).

To order a reference board please see [antenova.com](http://antenova.com)

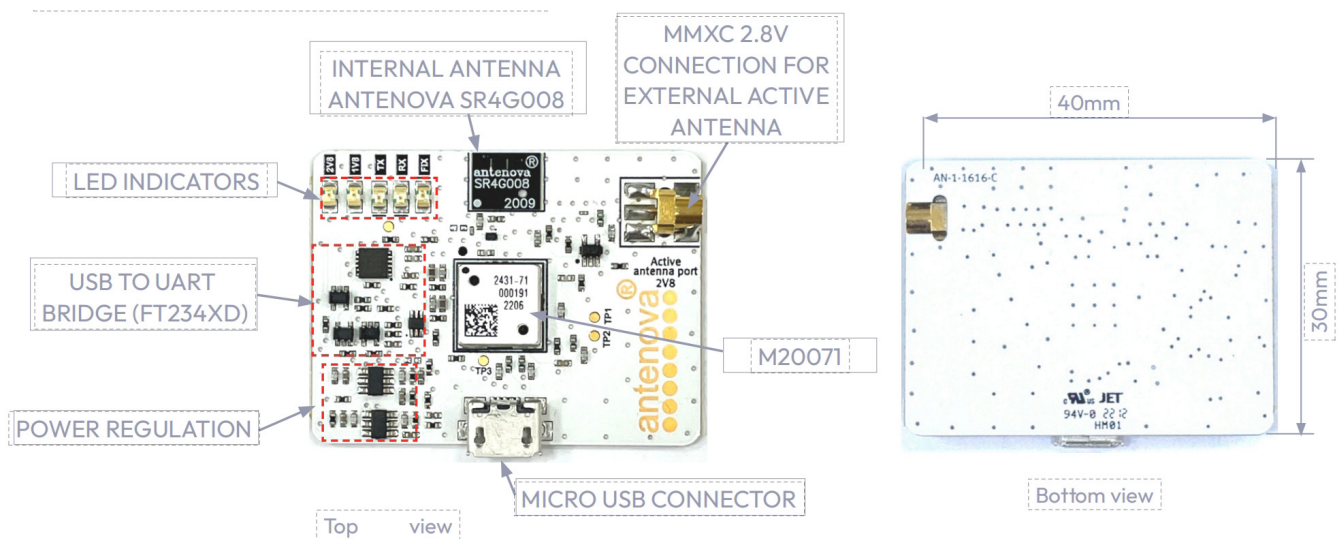

## 11.2. Antenna evaluation

Antenova offers a wide range of GPS/GNSS antenna solutions. The full Antenova range covers the L1 bands for GPS, GLONASS, Galileo, and Beidou. The range includes FPC (Flexible PCB antennas) & Surface Mount (SMD or Embedded), in both active and passive variants as well as an External antenna. The active antenna modules include an LNA and SAW. These modules are suited to designs that need additional filtering / gain with a low noise figure before the GNSS receiver. The Agosti SMD antenna is well suited to small PCBs of size 60x40mm. The Raptor GNSS antenna covers the GNSS L1+L2+L5 bands, and is suitable for applications requiring accurate positioning. All Antenova GNSS antennas are optimised for integration with the Antenova GNSS receiver modules. The website has details on each antenna in the range: <https://www.antenova.com/products/?technology=gps-gnss>

## 12. Reflow soldering

### 12.1. Placement

Typical placement systems used for any BGA/LGA package are acceptable.  
 Recommended nozzle diameter for placement: 5mm

### 12.2. Soldering paste

Use of “No Clean” soldering paste is strongly recommended, as it does not require cleaning after the soldering process has taken place. An example of suitable soldering paste is Alpha OM350.

### 12.3. Soldering

The recommended soldering profile for M20071 is shown below. However, it is the responsibility of the Contract Manufacturer to determine the exact reflow profile used, taking into consideration the parameters of the host PCB, solder paste used, etc.

PROFILE FEATURE		PB-FREE SOLDER
Pre-Heat	Temperature ( $T_s$ ) Min	130°C
	Temperature ( $T_s$ ) Max	220°C
	Time ( $t_s$ )	<150s
Reflow	Liquidus Temperature - ( $T_l$ )	220°C
	Time ( $t_l$ )	45-90s
Peak Package Body Temperature ( $T_p$ )		245°C
Time within 5°C of peak temp ( $t_p$ )		30s
Average Ramp up rate - $T_s$ (max) to ( $T_p$ )		3°C/s
Ramp Down Rate		6°C/s max

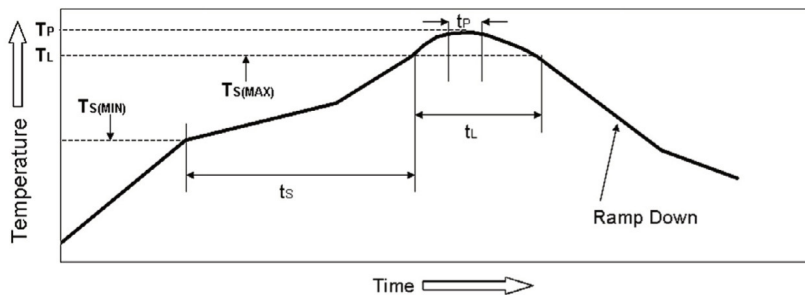

The Pb Free Process-Package Peak Reflow Temperature is 260°C.  
 Exceeding the maximum soldering temperature could permanently damage the module.

## 12.4. Multiple soldering

The M20071 module can be submitted up to 2 reflow soldering processes. Upside-down soldering is acceptable but it is recommended that the Contract Manufacturer qualify the process before mass production. The second reflow must take place within the recommended four life limit (MSL3). Please contact Antenova for further information.

## 12.5. Hand soldering

Hand-soldering and rework of the M20071 module is acceptable, however care must be taken to avoid short circuits due to the small size of the module pads.

## 13. Quality and environmental specifications

TEST	STANDARD	PARAMETERS
PCB inspection	IPC-6012B, Class 2. Qualification and Performance Specification for Rigid Printed Boards - Jan 2007	
Assembly inspection	IPC-A-610-D, Class 2 "Acceptability of electronic assemblies"	
Temperature range	ISO16750-3	-30 °C, +25 °C, +85 °C, operating
Moisture/Reflow sensitivity	IPC/JEDEC J-STD-020D.1	MSL3
Storage (Dry Pack)	IPC/JEDEC J-STD-033C	MSL3
Solderability	EN/IEC 60068-2-58 Test Td	More than 90% of the electrode should be covered by solder. Solder temperature 245 °C ± 5 °C

Moisture sensitivity:

Antenova ships all devices dry packed in tape on reel with desiccant and moisture level indicator sealed in an airtight package. If on receiving the goods the moisture indicator is pink in colour or a puncture of the airtight seal packaging is observed, then follow J-STD-033 "Handling and Use of Moisture/Reflow Sensitive Surface Mount Devices".

## 14. Hazardous material regulation conformance

---

The RF antenna module has been tested to conform to RoHS and REACH requirements. A certificate of conformance is available from Antenova's website.

## 15. Packaging

---

### 15.1. Optimal storage conditions

TEMPERATURE	-10°C to 40°C
HUMIDITY	Less than 75% RH
SHELF LIFE	24 Months
STORAGE PLACE	Away from corrosive gas and direct sunlight
PACKAGING	Reels should be stored in unopened sealed manufacturer's plastic packaging.
MSL LEVEL	3

Note: The M20071 modules meet MSL Level 3 of the JEDEC specification J-STD-020D - 168 hours Floor Life (out of bag)  $\leq 30$  °C/60% RH. If the stated floor life expires prior to reflow process then follow J-STD-033 "Handling and Use of Moisture/Reflow Sensitive Surface Mount Devices".

The shelf life of the antenna is 2 years provided the factory seal on the package has not been broken.

## 15.2. Tape characteristics

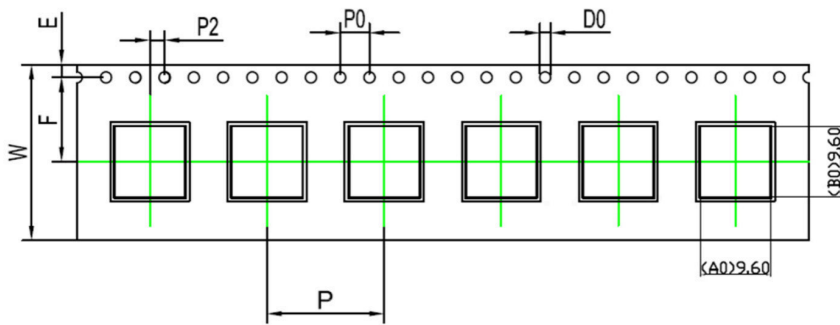

P0	P1	P2	D0
4.00 ± 0.1	16.00 ± 0.1	2.00 ± 0.1	1.55 ± 0.1

E	F	W
1.75 ± 0.1	11.50 ± 0.1	24.00 ± 0.3

All dimensions in (mm)

QUANTITY	LEADING SPACE	TRAILING SPACE
1000 pcs / reel	50 blank module holders	50 blank module holders

### 15.3. Reel dimensions

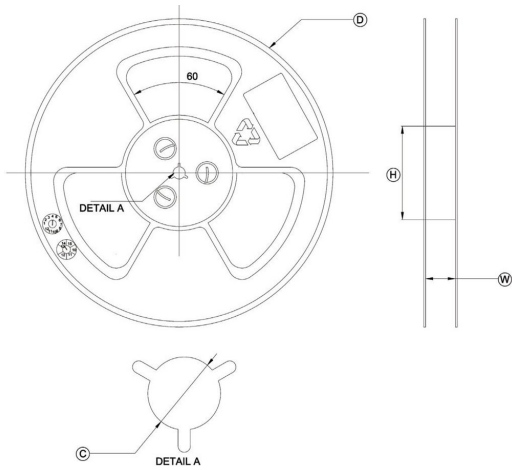

D	C	H	W
330.0 ± 2.0	13.3 ± 0.3	100.0 ± 3.0	24.5 ± 0.2

All dimensions in (mm)

### 15.4. Box dimensions

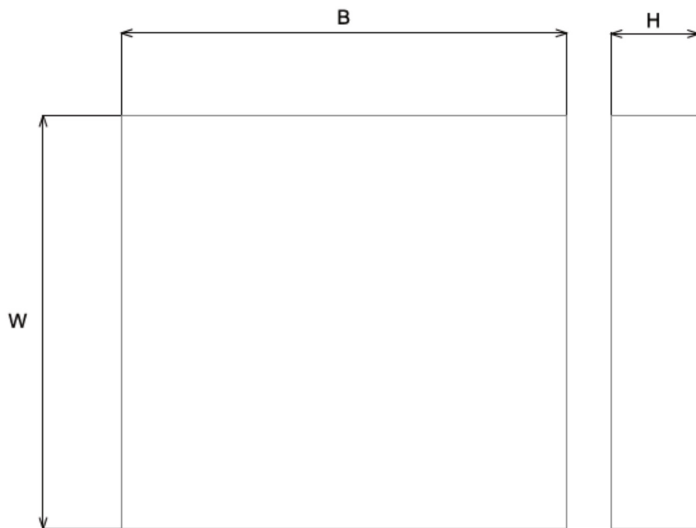

Width (W)	Breadth (B)	Height (H)
340mm	339mm	53mm

## 15.5. Bag properties

Reels are supplied in protective plastic packaging.

## 15.6. Reel label information

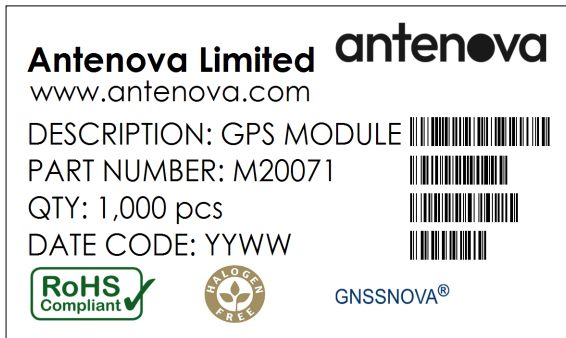

## Quality statements

Antenova's products conform to REACH and RoHS legislation. For our statements regarding these and other quality standards, please see [antenova.com](http://antenova.com).



Antenova reserves all rights to the contents of this document. Antenova gives no warranties based solely on the accuracy or completeness of the contents of this document and reserves the right to make changes to the specifications of the products described herein at any time and without notice.

## Datasheet version

2.01 released 1st June 2026

## Antenna design, integration and test resources

Product designers – the details contained in this datasheet will help you to complete your embedded antenna design. Please follow our technical advice carefully to obtain optimum antenna performance.

We aim to support our customers to create high performance wireless products. You will find a wealth of design resources, calculators and case studies to aid your design on our website.

Antenova's design laboratories are equipped with the latest antenna design tools and test chambers. We provide antenna design, test and technical integration services to help you complete your design and obtain the required certifications.

If you cannot find the antenna you require in our product range, please contact us to discuss creating a custom antenna to meet your exact requirements.

Share knowledge with RF Experts around the world

**ask.antenova** is a global forum for  
designers and engineers working with  
wireless technology

[Visit Ask.Antenova](#)

Visit [antenova.com](http://antenova.com)

**Order antenna samples and  
evaluation boards, and read our  
antenna resources**

[Visit antenova.com](#)

Request a volume quotation for antennas:

[\*\*sales@antenova.com\*\*](mailto:sales@antenova.com)

**+ 44 (0) 23 9400 1023**

Global headquarters

**Antenova Ltd, 7 The Briars,  
Waterberry Drive, Waterlooville,  
Hampshire, PO7 7YH**